

Size		d	n	L	D ₀	H	S	Unit:mm WEIGHT (kg)
A	B							
15	1/2	15	Rc 1/2	55	55	134.5	29	0.48
20	3/4	20	Rc 3/4	65	70	159	35	0.69
25	1	25	Rc 1	70	80	189	44	1.05
32	1 1/4	32	Rc 1 1/4	80	90	217	54	1.58
40	1 1/2	40	Rc 1 1/2	90	100	251	60	2.14
50	2	50	Rc 2	100	110	303	74	3.27

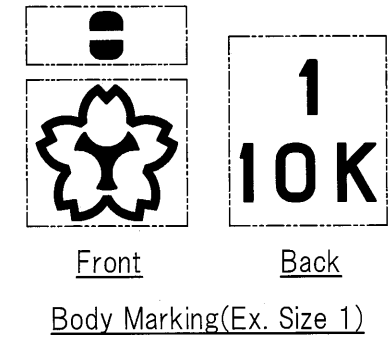

No.	Name of Parts	Materials	Q'ty	Descriptions
2-1	NUT	C3604BD	1	
209	PACKING	NON-ASBESTOS	1	
208	NAME PLATE	A1050P	1	
207	HAND WHEEL	ADC12	1	YELLOW GREEN
206	GLAND	C3604BD	1	
205	PACKING NUT	C3604BD	1	
204	STEM	C3531	1	
203	DISC	CAC406	1	
202	BONNET	CAC406	1	
201	BODY	CAC406	1	

TEST PRESSURE

BODY (Water)	2.10 MPa
SEAT (Water)	1.54 MPa

JIS B 2011 LEAD-CUT BRONZE 10K SCREWED GATE VALVE				FIGURE B10GN
Approval	Check	Drawing	Date	Scale
<i>[Signature]</i>	S.Vmo	T.KURISU	2023.01.17	
Yamato Valve Co., Ltd.				Drawing No. BBACI-R006G-E