

Size		d	L	D	H	H1	H2	L1	L2	S	D ₀	Weight (kgf)
A	B											
50	2	53.4	43	96	198	62	148	36	46	160	100	4.5
65	2 1/2	67	46	115	204.5	125	154.5					5.6
80	3	82		131	212	132.5	162					6.0
100	4	102	52	152	262.5	148	182.5	44	53	173.5	160	9.3
125	5	127.6	56	190	285.5	171	205.5					12.7
150	6	151.6		217	297.5	183	217.5					14.3
200	8	197	60	266	361.5	220	261.5	67	75	198	200	21.9

Maximum Permissible Working Pressure
1.0 MPa

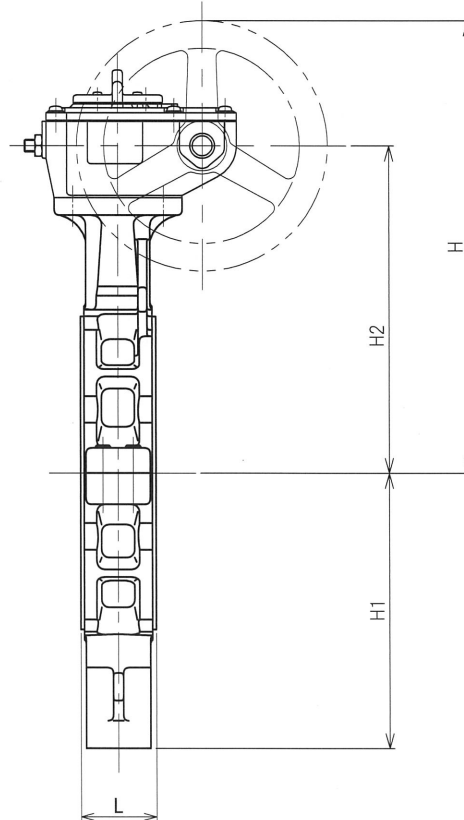

G21	WORM GEAR ACTUATOR	FC200	1	
12	SEATRING	PFA	1	
3	STEM	SUS329J1	1set	Size 200
		SUS316		Size 65~150
		SUS420J2		Size 50
2	DISC	SCS14	1	Size 65 over
		PFA	1	Size 50 Core Metal:SCS13
1	BODY	FCD-S	1	
No.	Name of Parts	Materials	Q'ty	Description
TEST PRESSURE		JIS B 2032		
FLANGE CONNECTION		JIS 5K / JIS 10K		
FOR HOT WATER SUPPLY				Figure
GEAR-TYPE DUCTILE CAST IRON BUTTERFLY VALVE				GKR
Approval	Check	Drawing	Date	Scale
<i>[Signature]</i>	<i>[Signature]</i>	T.Nishikawa	2022.05.10	
Yamato Valve Co., Ltd.				図番 GKR-61260-A