

| Size | | d | L | D | H | H1 | H2 | L1 | L2 | S | D ₀ | WEIGHT (kg) | |
|------|----|-------|----|-----|-------|-----|-----|------|-----|-----|----------------|-------------|-------|
| A | B | | | | | | | | | | | YZR | YZR-B |
| 50 | 2 | 56 | 43 | 91 | 201 | 57 | 166 | 22.5 | 26 | 85 | 70 | 1.0 | 1.1 |
| 65 | 2½ | 69 | 46 | 111 | 214 | 64 | 179 | | | | | 1.2 | 1.3 |
| 80 | 3 | 84 | 46 | 125 | 207 | 77 | 172 | | | | | 1.7 | 1.8 |
| 100 | 4 | 104 | 52 | 147 | 218 | 94 | 183 | 2.2 | 2.3 | | | | |
| 125 | 5 | 130 | 56 | 180 | 261 | 108 | 211 | 46 | 42 | 133 | 100 | 3.8 | 4.0 |
| 150 | 6 | 153.5 | 56 | 210 | 272 | 125 | 222 | | | | | 4.7 | 5.0 |
| 200 | 8 | 199 | 60 | 255 | 319.5 | 167 | 257 | 53 | 40 | 162 | 125 | 7.2 | — |
| 250 | 10 | 253 | 68 | 322 | 416 | 186 | 316 | 71 | 54 | 206 | 200 | 13 | — |
| 300 | 12 | 302 | 78 | 375 | 448 | 216 | 348 | | | | | 18 | — |

※ Size 200-300 is only YZR.

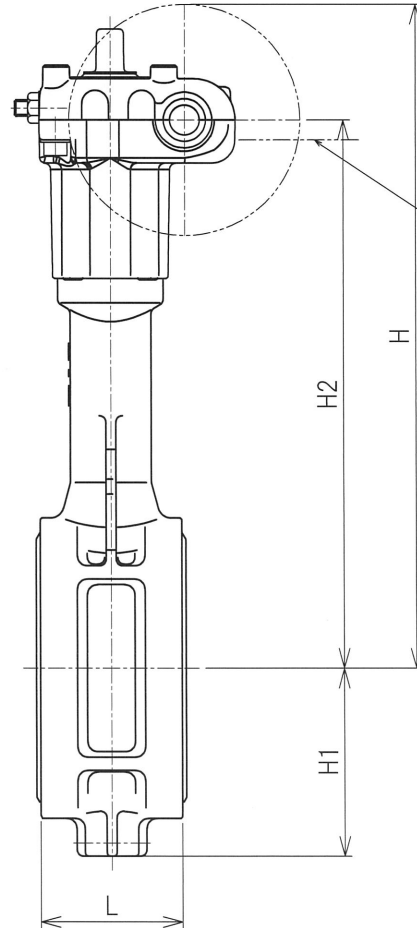
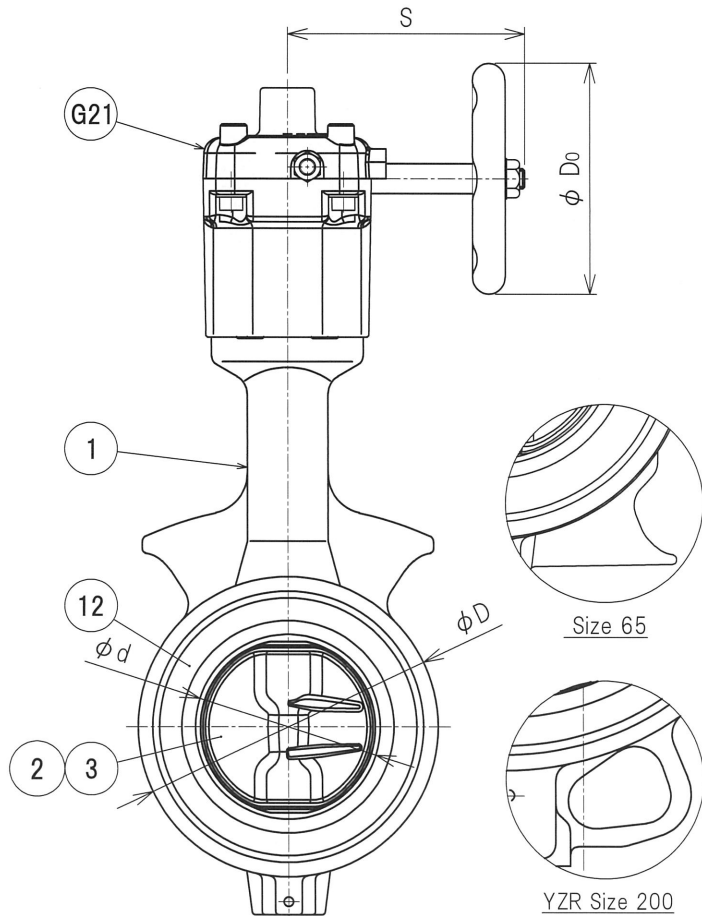

| Figure | Purpose | Maximum Permissible Working Pressure |
|--------|-----------------------|--------------------------------------|
| YZR | Condensation Measures | 1.0 MPa |
| YZR-B | Hot Water Supply | 1.0 MPa |

※ Please refer to a Catalogue
Consecutive use temperature ranges and use temperature ranges.

Surround a heat insulator to
two points of dot-dash line part.
(The position where a volt is covered)

| No. | Name of Parts | Materials | Q'ty | Descriptions |
|-----|--------------------|----------------|------|-------------------------------|
| G21 | WORM GEAR ACTUATOR | ADC12/RESIN | 1set | YZR-B : Orange YZR : Green |
| 12 | SEATRING | FKM EPDM | 1 | YZR-B YZR |
| 3 | STEM | SUS420J2 | 1set | |
| 2 | DISC | SCS14 SCS13 | 1 | YZR-B YZR |
| 1 | BODY | ADC12 | 1 | |

| | | | | |
|-------------------|--|------------------|--|--|
| Test Pressure | | JIS B 2032 | | |
| Flange Connection | | JIS 5K / JIS 10K | | |

JIS B 2032 CONFORMITY PRODUCT
GEAR-TYPE ALUMINIUM BUTTERFLY VALVES
Figure
YZR series

| Approval | Check | Drawing | Date | Scale |
|--------------------|--------------------|-------------|------------|-------|
| <i>[Signature]</i> | <i>[Signature]</i> | T.Nishikawa | 2022.05.10 | |